

What Generators Do and Regulators Ought To Originally Published in "Moss Motoring" in 1987

Most people first learn about generators at night on a back country road in the middle of nowhere. (Actually, about 100 yards from a house, but the middle of nowhere is so much more depressing.) You have one of those "English sports car needs minor electrical work" from the classified ads. Oh, the man who sold you the car was honest; the car was most certainly English and it did need electrical work. Anyway, after standing over the open engine compartment and alternately thumping on the generator, the control box, and the flashlight, you conclude that although flashlights improve with thumping, generators and control boxes don't.

Perhaps the best way to come to grips with old electrics is by gaining an understanding of what makes them work. Contrary to popular belief, the operation of a Lucas generator is not based on some magic incantation - it is based upon five fundamental properties of electricity and magnetism:

- 1) Electric current in a coiled wire will create a magnetic field.
- 2) Wrapping the coil of wire around a soft iron core will intensify the magnetic field.
- 3) The strength of the magnetic field will vary with the current in the wire.
- 4) Rotating a loop of wire in a magnetic field will induce a voltage in that loop of wire.
- 5) The strength of the induced voltage is dependent upon the strength of the magnetic field and the speed at which the loop of wire is rotated.

A generator is composed of five parts. The armature (1a) is made up of coils of wire wrapped around an iron core, and it is the armature which rotates when the generator pulley is turned. The brushes (1b) are the spring-loaded contacts which transfer current from the armature to the electrical system. The brushes actually rest against a segmented ring at one end of the armature called the commutator (1c). Inside the generator body are the field coils or field windings (1d). These consist of fine copper wire wrapped around the field poles, which are essentially pieces of soft iron. It is current in the field coils or windings that produces the magnetic field in which the armature rotates.

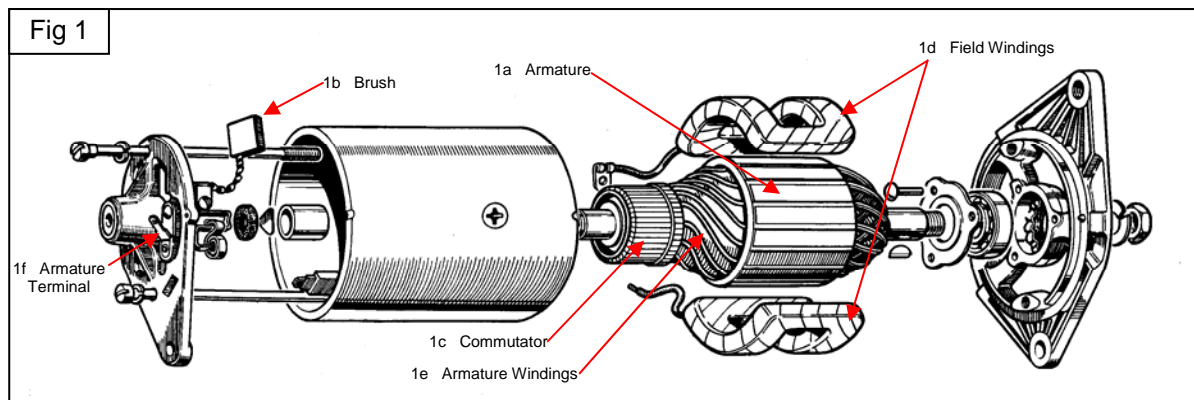

When the engine is turning over, the armature (1a) is spun by the fan belt. In the presence of a magnetic field generated by the field windings (1d), a voltage is induced (created) in the armature windings (1e). When the voltage in the armature windings (1e) is greater than the rest of the system, current will flow from the armature windings (1e) through the commutator (1c), through the brushes (1b), finally arriving at the armature terminal (1f) of the generator (usually marked "D"). The current then flows through the wire running to the "D" terminal of the control box or voltage regulator.

56 The control box (or voltage regulator as most of us call
 57 it) has two main parts. The cut-out relay (2e) prevents
 58 current from flowing to the generator from the battery
 59 when the generator's output voltage is lower than battery
 60 voltage. The second part of the control box is properly
 61 called the voltage regulator (2k). This strengthens or
 62 weakens the magnetic field in the generator according to
 63 the needs of the battery or other electrical system
 64 components. Remember, the stronger the magnetic
 65 field, the greater the voltage induced in the spinning
 66 armature. The cut-out relay (2e) consists of an iron core
 67 with two layers of wires wound around the core. The
 68 inner wrapping of wire is called the "shunt windings" and
 69 the outer wrapping is called the "series windings". The
 70 shunt windings, which are hidden under the series
 71 windings, are connected between the armature terminal
 72 "D" on the generator and a ground terminal (usually
 73 marked "E") on the control box.
 74

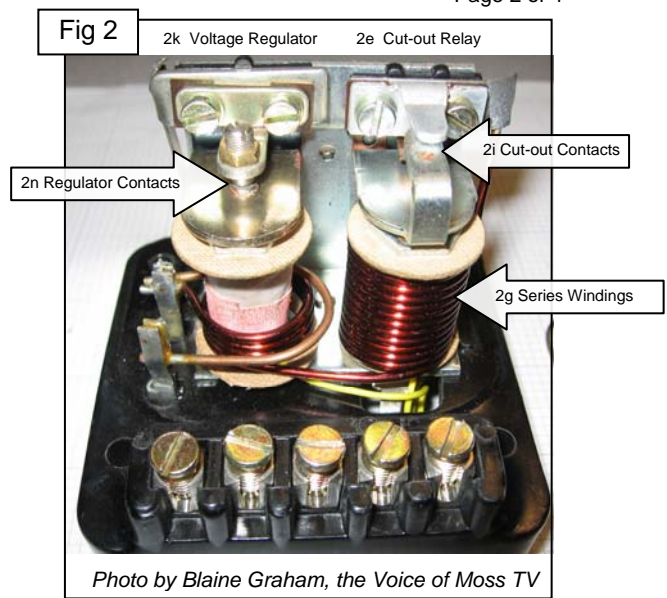
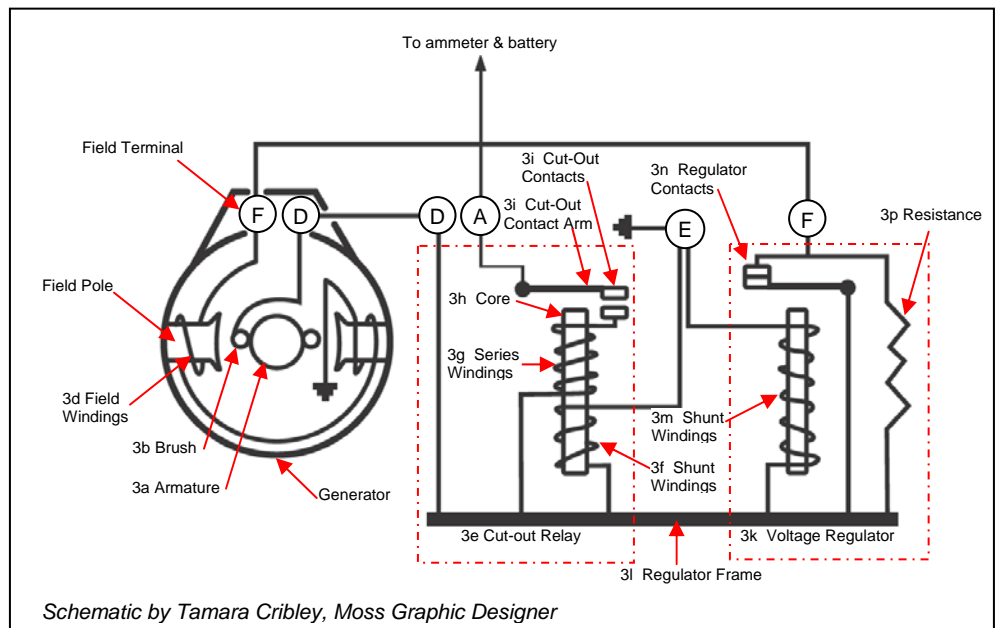

Photo by Blaine Graham, the Voice of Moss TV

75 This means that the internal generator voltage is always impressed upon the shunt windings. All the generator
 76 output current passes through the series windings (2g, 3g) before going to the electrical system in general.
 77

78 Fixed above the cut-out
 79 core is a spring arm that
 80 carries a contact (2i, 3i)
 81 which is connected to the
 82 series windings (2g,3g) of
 83 the cut-out core. Output
 84 current from the generator
 85 can only pass on to the
 86 electrical system and the
 87 battery when the cut-out
 88 contact arms (2i,3i) are
 89 touching. Spring tension
 90 normally holds the contacts
 91 apart so there can be no
 92 current flow in either
 93 direction.
 94



Schematic by Tamara Cribley, Moss Graphic Designer

99 When the armature in the generator is spinning fast enough, (about 1000 generator RPM or 750 engine
 100 RPM) the current in the shunt windings (3f) of the cut-out relay will generate a magnetic field strong
 101 enough to overcome the natural spring tension of the contact arm (3i) and it snaps down bringing the two
 102 contacts together. Current now flows through the series windings (3g), across the contacts and out the
 103 arm (3i), finally reaching the output terminal (usually "A") on the control box. From there, it goes on to the
 104 ammeter (if fitted) and then to the battery. This current now flowing through the series windings (3g)
 105 actually intensifies the magnetic field around the core (3h) of the cut-out relay, and this in turn holds the
 106 arm down even more firmly, pressing the contacts (3i) together. The point when the contacts close is
 107 usually adjusted so that the internal voltage of the regulator is about 12.7 to 13 volts.
 108

109 When the engine slows to idle, the armature slows down as well. This means that the voltage induced in
 110 the spinning armature (3a) drops. Lower voltage reduces the strength of the magnetic field holding the
 111 series winding's contacts (3i) closed. Eventually, the weakened magnetic field can no longer hold against

112 the arm's spring tension and the contacts open. (Note: the way in which the contacts open is actually
113 somewhat more complex, but this description will do for our purposes.) This immediately stops all current
114 flow to or from the generator. The point at which the contacts open (around 8.5 to 11 volts) is known as
115 the drop-off point. If the series winding contacts in the cut-out relay did not open at low generator output,
116 the higher battery voltage would flow back through the control box, through the wiring harness and into
117 the armature's fine wire windings in the generator. The reverse current flow would melt the windings and
118 thus destroy the generator. Now you know one of the reasons why the control box is so important.

119
120 The other half of the control box, the voltage regulator (2k, 3k), acts to limit the voltage in the charging
121 system to a safe value by controlling the internal voltage of the generator. The voltage regulator, like the
122 cut-out, has a shunt winding (3m) made up of many turns of fine wire wrapped around a soft iron core.
123 Suspended above the regulator core are a pair of contact points (3n), similar to the cut-out relay.
124 However, these points are normally closed, rather than open. When the points are closed, the output
125 current from the "D" terminal on the generator goes through the regulator frame (3l), through the regulator
126 contacts (3n) to the field terminal on the control box (usually "F"). From this field terminal, the current
127 flows to the field terminal ("F") on the generator and then through the field windings (3d) around the field
128 poles of the generator. The current in the field windings (3d) creates the magnetic field around the
129 armature (3a). The armature spinning inside this magnetic field generates the electric current that feeds
130 the battery and the rest of the electrical system. The function of the regulator is to break this connection.

131
132 When the generator is spinning slowly, generator output voltage is low. This means the current in the
133 regulator shunt windings (3m) is weak, and the magnetic field created by this weak current is unable to
134 overcome the spring tension in the arm holding the regulator contact points (3n) closed. As we spin the
135 generator faster, the output voltage increases. As a result, we see increased current flowing into the
136 voltage regulator through the "D" terminal. This increased current continues, flowing through the regulator
137 shunt windings (3m), through the regulator contacts (3n), out through the "F" terminal on the voltage
138 regulator and back through the field windings (3d) in the generator. Since we have a direct connection
139 through the regulator contacts (3n), current in the field windings (3d) increases as the generator spins
140 faster. Consequently, the magnetic field (in which the armature spins) created by the increased current in
141 the field windings (3d) is also increasing. Because the magnetic field is stronger, the induced voltage in
142 the armature is also increasing. As the output voltage from the generator continues to increase, the
143 current in the shunt windings (3m) of the regulator relay also increases, which increases the strength of
144 the magnetic field trying to pull the regulator contacts (3n) apart.

145
146 When the generator output is high enough, the strength of the magnetic field generated by the current in
147 the regulator shunt windings (3m) finally overcomes the natural tension of the contact arm and the
148 regulator contacts (3n) are separated. The direct connection between the armature terminal "F" of the
149 generator and the field terminal "F" of the control box is broken. Although the direct connection has been
150 severed, there is still a way for the current from the generator to return to the field windings.

151
152 This second path is through a short piece of resistance wire (3p) connecting the regulator frame (3l) to the
153 "F" terminal on the voltage regulator. Output current from the generator can still get to the field windings in
154 the generator, but the built-in resistance of the wire reduces the current passing through the field windings
155 (3d) which reduces the strength of the magnetic field in which the armature is spinning. The voltage
156 induced by the magnetic field in the armature windings falls, and so generator output falls as well. With
157 reduced generator output, the current in the shunt windings (3m) of the regulator is also reduced, and the
158 magnetic field produced by the current in the shunt windings is likewise reduced. When the strength of
159 the magnetic field is no longer enough to hold the regulator contacts (3n) apart against the spring tension
160 in the arm, they snap back together, and direct contact between the generator output and the field
161 windings is restored.

162
163 Since current is no longer flowing through the resistance wire, the current in the field windings (3d) of the
164 generator is increased, which strengthens the magnetic field inside the generator. The induced voltage in
165 the armature increases, and the generator output also increases. As generator output increases, current
166 in the shunt windings (3m) of the regulator increases once again until the magnetic field is strong enough
167 to pull the regulator contacts (3n) apart. As before, with the direct connection broken, the current to the

