

ASSEMBLY INSTRUCTIONS

FOR

SUPERLITE 6 BIG BRAKE FRONT HAT KIT PRO STREET APPLICATION, 13.06" DIAMETER VENTED ROTOR

2005 - PRESENT MUSTANG (5 LUG, STOCK OFFSET)

PART NUMBER GROUP

140-9109

WARNING

INSTALLATION OF THIS KIT SHOULD **ONLY** BE PERFORMED BY PERSONS EXPERIENCED IN THE INSTALLATION AND PROPER OPERATION OF DISC BRAKE SYSTEMS. IT IS THE RESPONSIBILITY OF THE PERSON INSTALLING ANY BRAKE COMPONENT OR KIT TO DETERMINE THE SUITABILITY OF THE COMPONENT OR KIT FOR THAT PARTICULAR APPLICATION.

RACING EQUIPMENT AND BRAKES MUST BE MAINTAINED AND SHOULD BE CHECKED REGULARLY FOR FATIGUE, DAMAGE AND WEAR.



WARNING

DO NOT OPERATE ANY VEHICLE ON UNTESTED BRAKES!

BEFORE OPERATING VEHICLE, TEST THE BRAKES UNDER CONTROLLED CONDITIONS IN A SAFE AREA. TEST THE SYSTEM IN STATIC CONDITIONS FOR PROPER PEDAL HEIGHT AND THE ABILITY TO HOLD PRESSURE BEFORE ATTEMPTING TO MOVE THE VEHICLE. MAKE SEVERAL STOPS IN A SAFE AREA AT SLOW SPEEDS AND GRADUALLY WORK UP TO NORMAL OPERATING CONDITIONS. **ALWAYS** UTILIZE SAFETY RESTRAINT SYSTEMS AND ALL OTHER REQUIRED SAFETY EQUIPMENT WHILE OPERATING THE VEHICLE.

IMPORTANT

READ THE DISCLAIMER OF WARRANTY INCLUDED IN THE KIT.

WARNING: Some cleaners may stain or remove the finish on brake system components. Test the cleaner on a hidden portion of the component before general use.

Important Notice - Read This First

Before any tear-down or disassembly begins, review the following information:

- Review the wheel clearance diagram (figure 2, page 3) to verify that there is adequate clearance with the wheels you will be using with the installation.
- Front brake kits do not include flex lines. OEM brake lines will not adapt to Wilwood calipers. Check the assembly instructions, or associated components section for brake line recommendations before assembly. In addition, Wilwood offers an extensive listing of brake lines and fitting on our web site: www.wilwood.com.
- Due to OEM production differences and other variations from vehicle to vehicle, the fastener hardware and other components in this kit may not be suitable for a specific application or vehicle.
- It is the responsibility of the purchaser and installer of this kit to verify suitability / fitment of all components and ensure all fasteners and hardware achieve complete and proper engagement. Improper or inadequate engagement can lead to component failure.

Exploded Assembly Diagram

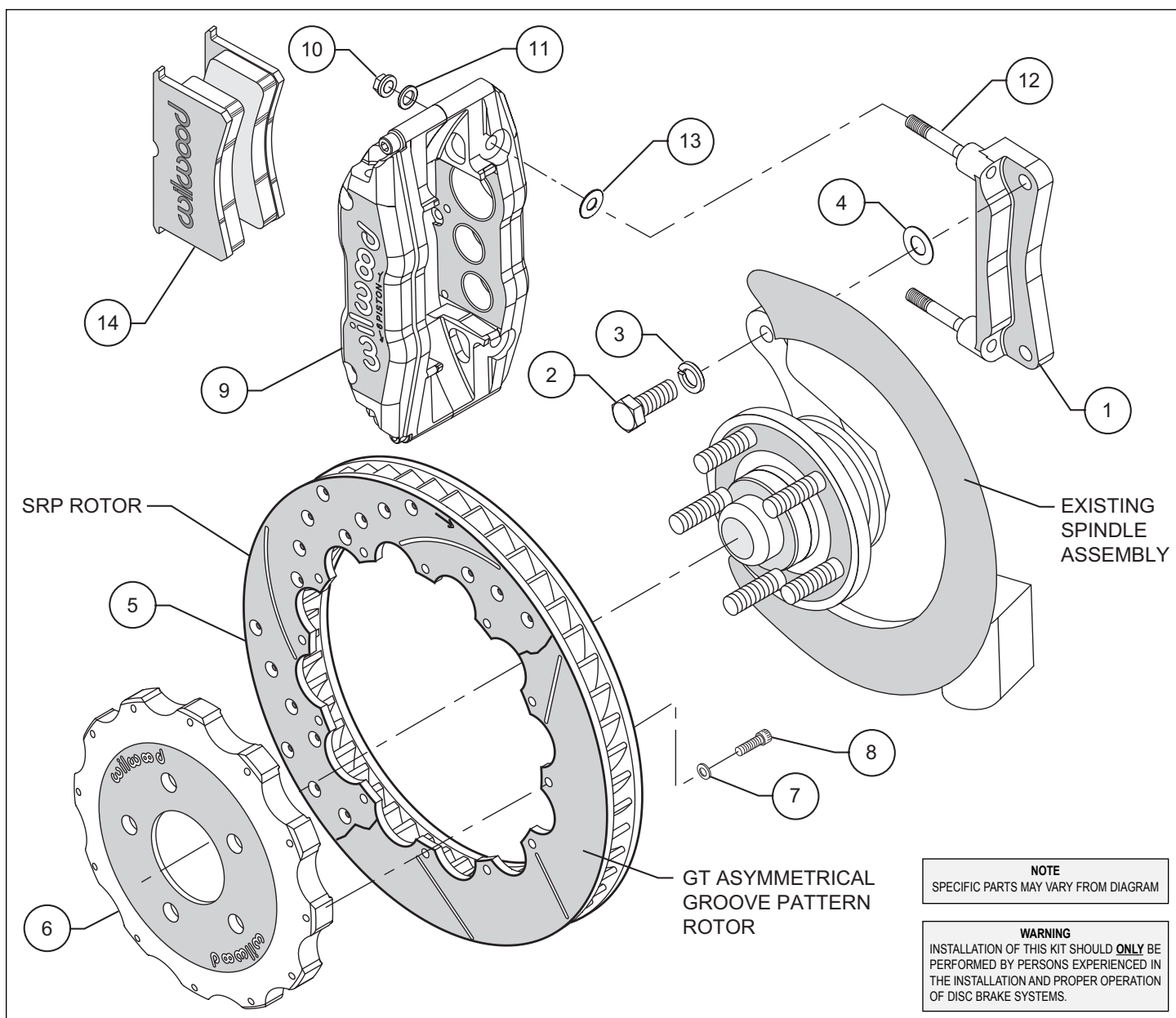

Figure 1. Typical Installation Configuration

Parts List

ITEM NO.	PART NO.	DESCRIPTION	QTY
1	250-9129	Bracket, Caliper Mounting	2
2	230-8818	Bolt, M12-1.75 x 40mm Long, HXHD	4
3	240-9202	Washer, Lock, M12 I.D. x 21.1mm O.D.	4
4	240-6320	Washer, .483 I.D. x 1.031 O.D.	8
5	160-8165/66	Rotor, GT, 1.25" Thk x 13.06" Dia, 12 x 8.75" Bolt Circle (one each, right and left)	2
5A	160-7798/99	Rotor, SRP Drilled and Slotted (one each, right and left)	2
6	170-9128	Hat, 5 x 4.50, .715 Offset, 12 x 8.75 BC, Front	2
7	240-2509	Washer, .250 I.D. x .500 O.D. x .063 Thick	24
8	230-6737	Bolt, 1/4-20 x 1.00 Long, 12PT CS	24
9	120-8000/01-RS	Caliper, Billet Superlite 6R	2
10	230-6001	Nut, Self-Locking Hex Head	4
11	240-2510	Washer, .391 I.D. x .625 O.D. x .057 Thick	4
12	230-6232	Stud, 3/8-16 x 3/8-24 x 2.50 long (pre installed in bracket)	4
13	240-1159	Washer, .375 I.D. x .875 O.D. x .035 Thick	8
14	150-8855K	Pad, BP-10 Compound, Axle Set	1

NOTES:

Part Number 230-9203 Spindle Bolt Kit, includes part numbers 230-8818, 240-9202 and 240-6320

Part Number 230-4572 Rotor Bolt Kit, includes part numbers 230-6737 and 240-2509

Part Number 250-9130 Caliper Bracket Mounting Bolt Kit, includes P/N's 230-6001, 230-6232, 240-1159, 240-2510 and 250-9129

Item 5A is an optional item and is included in the (D) kits. Add "-D" to end of part number when ordering

Wilwood offers an optional Braided Stainless Steel Hose Kit. Order part number 220-9111 (not included in kit)

General Information and Disassembly Instructions

Installation of this kit should **ONLY** be performed by persons experienced in the installation and proper operation of disc brake systems. Before assembling the Wilwood front disc brake kit, double check the following items to ensure a trouble-free installation.

- Make sure this is the correct kit to match the exact make and model year of the vehicles spindle (i.e., brakes for a 1990 Mustang spindle will not fit a 2005 Mustang spindle).
- Verify the factory hub stud pattern matches the brake hat in this kit.
- Verify your wheel clearance using Figure 2.
- Inspect the package contents against the parts list to ensure that all components and hardware are included.

Disassembly

- Disassemble the original equipment front brakes:

Raise the front wheels off the ground. Support the front suspension by placing jack stands under the lower control arms. The lower control arms **MUST** be supported. The vehicle's weight must be on jack stands and not supported by a car jack or hoist.

Remove the wheel. Remove the two bolts from the backside of the spindle that hold the stock caliper mounting bracket and lift off the bracket and stock caliper as one unit. If space is a problem, you may have to unbolt the stock caliper from the caliper bracket before removal. Then slide off the stock hat and rotor assembly. Optional: Removal of the dust face plate to facilitate easy removal of additional parts and/or for aesthetic purposes if you will be running spoked wheel and would like to see the drilled/slotted rotor.

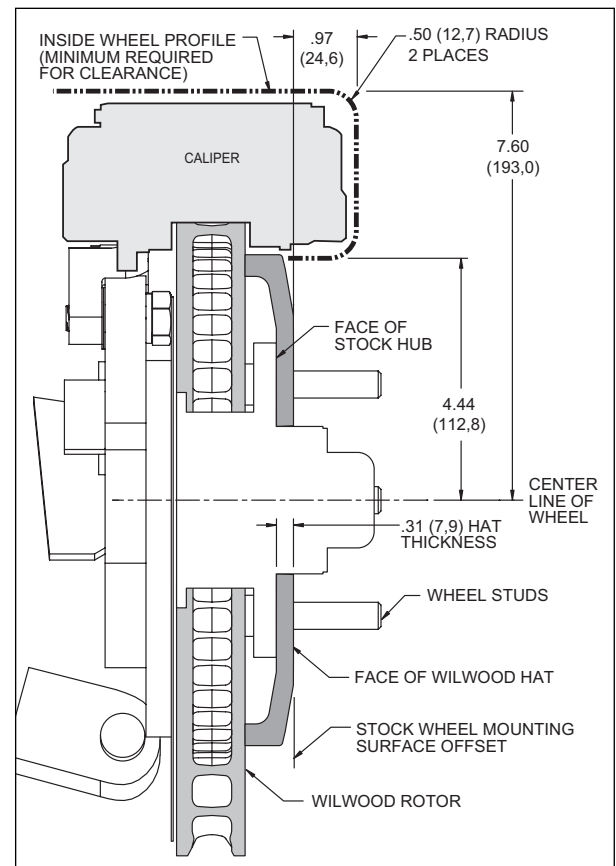

Figure 2. Wheel Clearance Diagram

- Clean and de-grease the spindles as well as the stock caliper bracket bolts. Remove all nicks or burrs on the spindle snout and threads.

Assembly Instructions

Assembly Instructions (numbers in parenthesis refer to the part list (above) and diagram on the preceding page): **CAUTION:** All mounting bolts must fully engage insert nuts. Be sure to check that all bolts are either flush or protruding through flanged side of insert nut after shimming.

- The caliper mounting bracket assembly (1) should be installed first with clean, dry threads on the mounting bolts. The bracket must tighten squarely against the outboard side of the caliper mount bosses on the spindle body. Inspect for interference from casting irregularities, machining ridges, burrs, etc. Slide bolt (2) through lock washer (3) then through the hole in the spindle body where the OEM bolt was removed. Use one thin shim (4) between the bracket and spindle during initial trial fitting. Later, after the caliper, pad and rotor alignment have been checked, and any necessary shims have been put in place, the mount bolts (2) should be coated with red *Loctite*® 271 and torqued to 47 ft-lb.

- With the larger I.D. side of the rotor (5) facing away from the hat (6), bolt rotor (5) to hat (6) through the backside of the rotor using washers (7) and bolts (8). Torque bolts (8) to **85 in-lb**. Safety wire bolts (8) using standard 0.032 inch diameter stainless steel safety wire as shown in Figure 3. Please refer to Wilwood's data sheet DS-386 (available at www.wilwood.org/ds386.pdf) for complete safety wire installation instructions. Slide the rotor/hat assembly onto the spindle. Install a couple of lug nuts (hand tighten) to keep the rotor/hat assembly in place while continuing with the installation.

- NOTE:** Please reference the caution statement at the beginning of the assembly instructions. With the bleed screws pointing up, mount the caliper (9) onto the caliper bracket (1) with the self locking hex nut (10), flat washer (11), through the top of the caliper and mounting stud (12) with flat washer (13) positioned between caliper (9) and caliper mounting bracket (1). Finger tighten. Check to see that the top of the rotor is aligned with the top of the brake pad. If adjustment is necessary, add or subtract flat washers (13). View the rotor (5) through the top opening of the caliper (9). The rotor (5) should be aligned in the center of the caliper (9). If not, adjust the caliper (9) by using 0.033 inch thick shims (4) placed between the spindle assembly and the caliper mounting bracket (1). Finger tighten and recheck alignment. Apply red *Loctite*® 271 to bolt threads (12) and torque to 30 ft-lb.

- Remove the bridge bolt from the caliper (9) and install the disc brake pads (14). Reinstall the caliper bridge bolt.

- Remove the two lug nuts that were used to hold the rotor/hat assembly in place during caliper installation.

- NOTE:** OEM rubber brake hoses will not adapt to Wilwood calipers and should not be used. The caliper inlet fitting is a 1/8-27 NPT. Use steel adapter fittings at the caliper, either straight, 45 or 90 degree and enough steel braided line to allow for full suspension travel and turning radius, lock to lock. **Carefully route lines to prevent contact with moving suspension, brake, or wheel components.** Periodically check hose and components for any wear. Wilwood brake and hose kits are designed for use in many different vehicle applications and it is the installer's responsibility to properly route and ensure adequate clearance and retention for brake hose components. An optional Wilwood flex line kit, part number 220-9111 is available and includes all the lines, fitting, etc. (not included with the kit). This optional flex line kit also includes a new flex line bracket. You will need to remove the OEM bracket (retain OEM hardware) and replace with the new bracket utilizing the OEM hardware.

- Bleed the brake system. Reference the general information and recommendations on the last page as necessary for proper bleeding instructions.

- Install the wheel and lug nuts, torque to OEM specifications.

- Repeat the procedure for the other wheel.

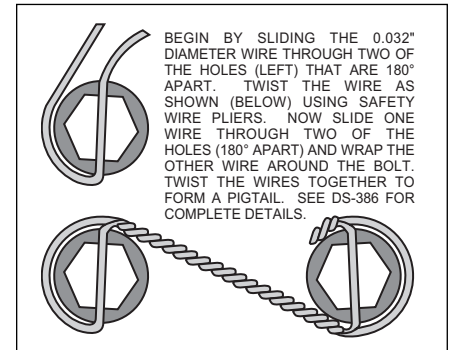

Figure 3. Safety Wire Diagram

Additional Information and Recommendations

- Please read the following concerning balancing the brake bias on 4 wheel disc vehicles.

This Mustang kit can be operated using the stock OEM master cylinder. However, as with most suspension and tire modifications (from OEM specifications), changing the brakes may alter the front to rear brake bias. Rear brakes should not lock up before the front. Brake system evaluation and tests should be performed by persons experienced in the installation and proper operation of brake systems. Evaluation and tests should be performed under controlled conditions. Start by making several stops from low speeds then gradually work up to higher speeds. Always utilize safety restraint systems while operating vehicle.

- For optimum performance, fill and bleed the new system with Wilwood Hi-Temp[®] 570 grade fluid or EXP 600 Plus. For severe braking or sustained high heat operation, use Wilwood EXP 600 Plus Racing Brake Fluid. Used fluid must be completely flushed from the system to prevent contamination. **NOTE:** Silicone DOT 5 brake fluid is **NOT** recommended.

- To properly bleed the brake system, begin with the caliper farthest from the master cylinder. Bleed the outboard bleed screw first, then the inboard. Repeat the procedure until all calipers in the system are bled, ending with the caliper closest to the master cylinder. **NOTE:** When using a new master cylinder, it is important to bench bleed the master cylinder first.

- Test the brake pedal. It should be firm, not spongy and stop at least 1 inch from the floor under heavy load. If the brake pedal is spongy, bleed the system again.

If the brake pedal is initially firm, but then sinks to the floor, check the system for fluid leaks. Correct the leaks (if applicable) and then bleed the system again.

If the brake pedal goes to the floor and continued bleeding of the system does not correct the problem, a master cylinder with increased capacity (larger bore diameter) may be required. Wilwood offers various lightweight master cylinders with large fluid displacement capacities.

- NOTE:** With the installation of after market disc brakes, the wheel track may change depending on the application. Check your wheel offset before final assembly.

- If after following the instructions, you still have difficulty in assembling or bleeding your Wilwood disc brakes, consult your local chassis builder, or retailer where the kit was purchased for further assistance.

PAD BEDDING PROCEDURE:

- Pump brakes at low speed to assure proper operation. On the race track, or other safe location, make a series of hard stops until some brake fade is experienced. Allow brakes to cool while driving at moderate speed to avoid use of the brakes. This process will properly burnish the brake pads, offering maximum performance.

Associated Components

PART NO.	DESCRIPTION
260-1874	Wilwood Residual Pressure Valve (2 lb for disc brakes)
260-1876	Wilwood Residual Pressure Valve (10 lb for drum brakes)
260-8419	Wilwood Proportioning Valve
290-0632	Wilwood Racing Brake Fluid (Hi-Temp [®] 570) (12 oz)
290-6209	Wilwood Racing Brake Fluid (EXP 600 Plus) (16.9 oz)
340-1285	Wilwood Floor Mount Brake Pedal (with balance bar)
340-1287	Wilwood Swing Mount Brake Pedal (with balance bar)
260-6764	Wilwood 3/4 inch High Volume Aluminum Master Cylinder
260-6765	Wilwood 7/8 inch High Volume Aluminum Master Cylinder
260-6766	Wilwood 1 inch High Volume Aluminum Master Cylinder
260-4893	1-1/16 inch Tandem Master Cylinder (aluminum housing)
250-2406	Mounting Bracket Kit (tandem master cylinder)
260-8555	Wilwood 1 inch Aluminum Tandem Chamber Master Cylinder
260-8556	Wilwood 1-1/8 inch Aluminum Tandem Chamber Master Cylinder
350-2038	1971 - 1973 Pinto Rack and Pinion (new, not rebuilt)
270-2016	Quick Release Steering Hub (3/4 inch shaft)
270-2017	Quick Release Steering Hub (5/8 inch shaft)
220-9111	Flex Line Kit, 2005 Mustang

Bolt Torque Specifications

BOLT SIZE	TORQUE
1/4-20	85 in-lb
1/4-28	103 in-lb
5/16-18	180 in-lb
5/16-24	198 in-lb
3/8-16	22 ft-lb
3/8-24	30 ft-lb
7/16-14	42 ft-lb
7/16-20	47 ft-lb
1/2-13	65 ft-lb
1/2-20	77 ft-lb
9/16-12	95 ft-lb
9/16-18	105 ft-lb
5/8-11	110 ft-lb
5/8-18	120 ft-lb

NOTE: This bolt torque specification list is for use with specific grades of bolts as supplied in the particular Wilwood kit and is not intended as a guide for any other application.